

Casting Process

Lec 18 - 20

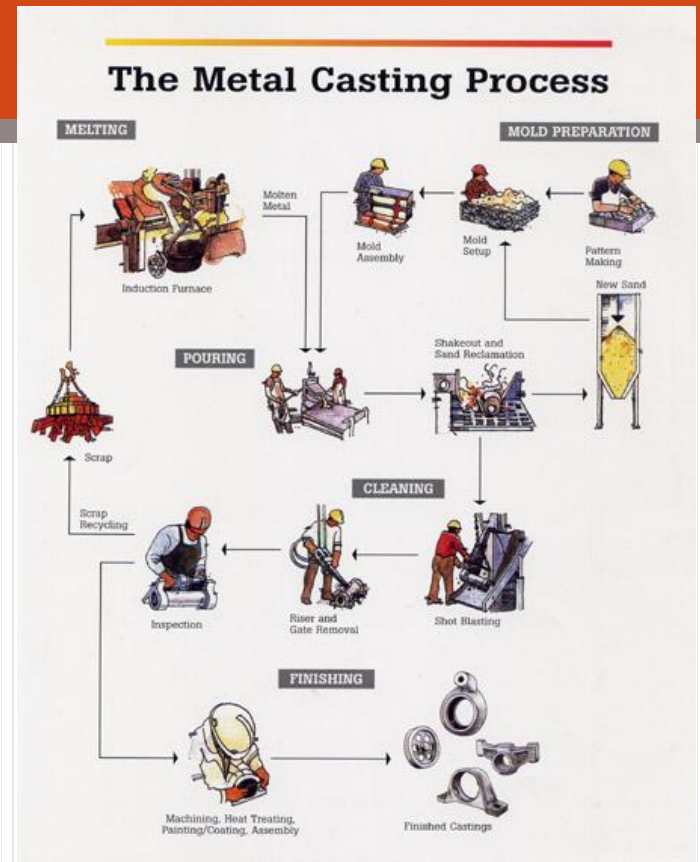

The Metal Casting Process

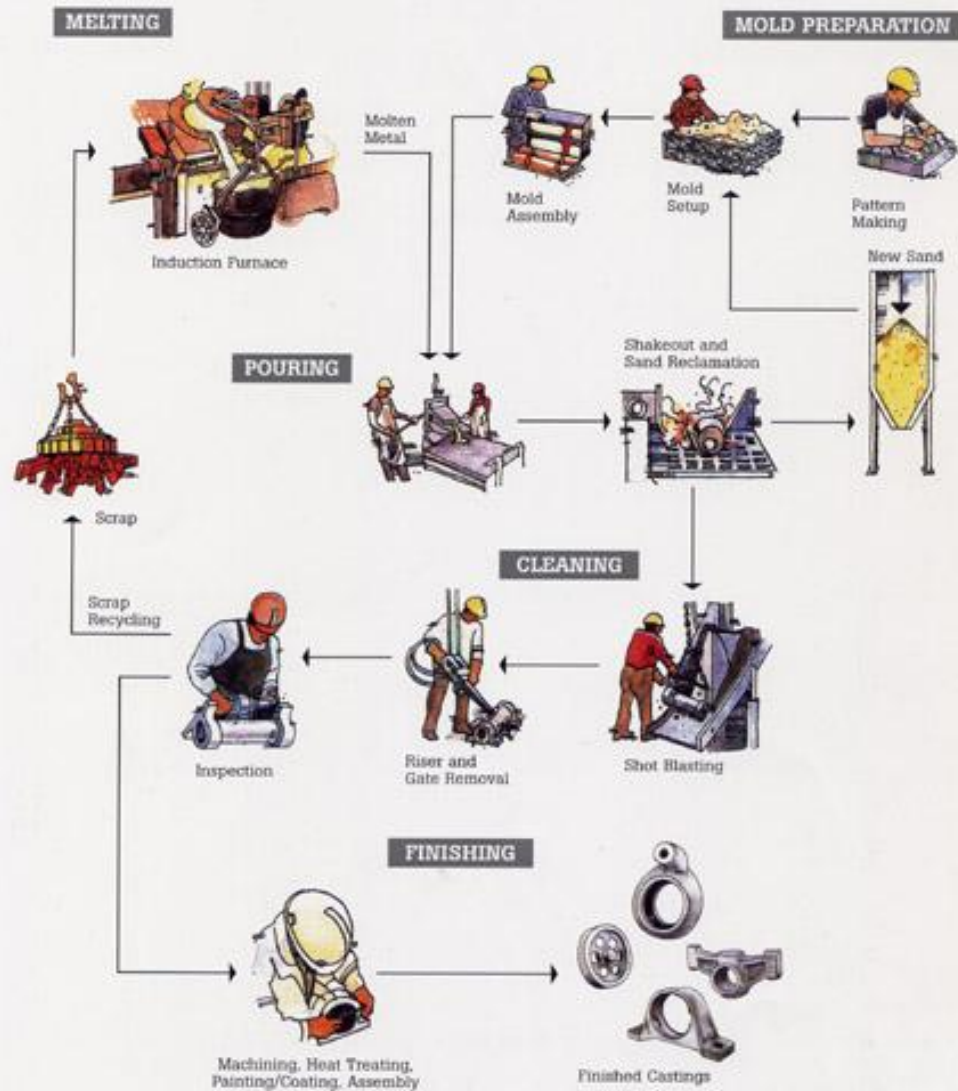

Introduction

- casting may be defined as a metal object obtained by pouring molten metal in to a mould and allowing it to solidify.
- Casting process is based on the property of liquids to take up the shape of the vessel containing it.
- Molten metal when poured in to a cavity of desired shape (called mould) flows in to every nook and corner of the cavity and fills all the shape.
- The section of the work shop where metal castings are produced is known as the foundry or foundry shop.

- The range of products that can be manufactured by the casting process vary from a small nail to very big components and simple shapes to very intricate shapes, which cannot be manufactured by any other processes. For example, the *largest cannon in the world*, situated at *Jaigarh fort, Jaipur*, weighing **50 tons**, was manufactured by the process of casting in the seventeenth century



The Sand Casting Process

- The most common method of making castings is using sand moulds. Sand moulds are made by ramming sand in metallic or wooden flasks. Such a casting process is commonly called sand casting process.
- The basic sequence of the operations required for making metal castings are:
 1. Pattern making
 2. Mould making Core making
 3. Melting of metal and pouring
 4. Cooling and solidification
 5. Cleaning of castings and inspection.

- The **cavity** in the mould is a replica of the casting required. This cavity of desired size and shape is made with the help of a *pattern*.
- A **pattern** is defined as a model of a casting. It is constructed in such a way that it can be used for forming an impression in sand or other material used for making the mould.
- The process of making patterns is an important step in the casting process. A pattern has to be made before making a mould. Various types of patterns are needed to make different shaped castings.

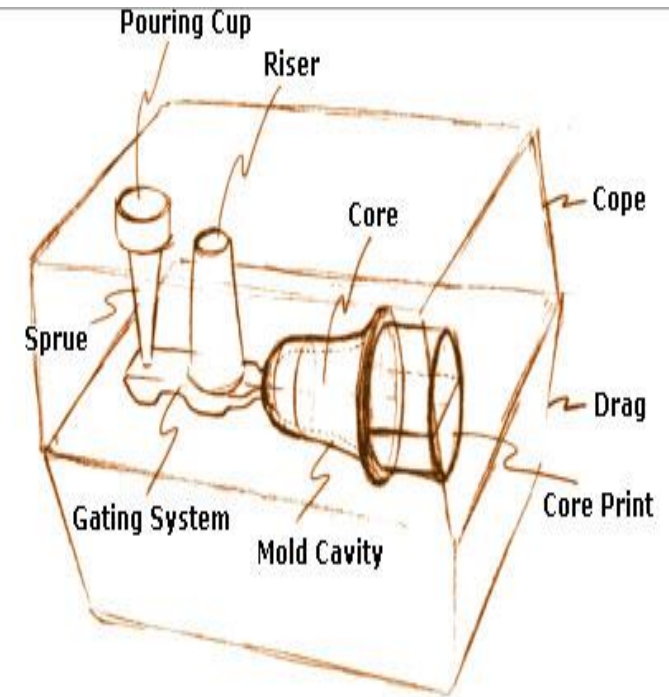

Typical Components of a Two-part Sand Casting Mold.

- Many castings may require holes or other internal hollow spaces, which must not be filled by the metal. To get these hollow spaces, *cores* are used in moulds.
- A **core** is a predetermined shape of mass of dry sand or other mould material, which is made separately from mould, and placed in the mould before pouring the molten metal.
- The process of making the core is different from the process of making moulds. It is used to obtain a shape in a casting, which cannot be obtained by the mould.

A mould pattern and core box for simple casting

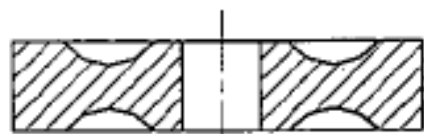

Required casting

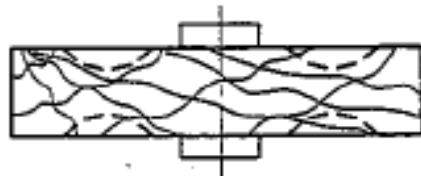

Pattern



Core box

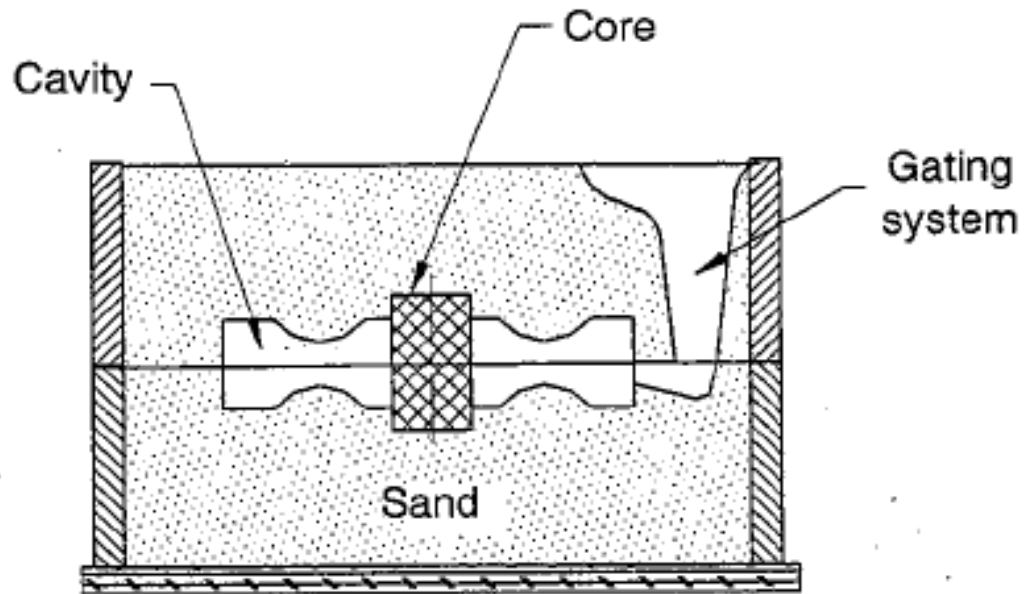

Cavity

Core

Gating system

Sand

Sand mould in two-piece flask

Pattern Making

- Patterns are the foundry man's mould forming tool.
- Pattern is used to form the mould cavity in which molten metal is poured.
- Pattern making involves study of materials used for making patterns, various types of patterns and pattern allowances.

Pattern materials

- A pattern for multiple uses must last long and, therefore, must be made from a suitable material.
- The materials commonly used for pattern making include wood, metals and alloys, plasters, plastic, rubber, and wax.
- The selection of the material for a pattern depends upon the type of moulding material used, number of castings to be produced, degree of dimensional accuracy required and so on.

The material selected for making a pattern should fulfill the following requirements:

1. It should be easily shaped, worked, machined and joined.
2. It should be resistant to wear and corrosion.
3. It should be resistant to chemical action.
4. It should be dimensionally stable and must remain unaffected by variations in temperature and humidity.
5. It should be easily available and economical.

characteristics of Commonly used pattern materials are

Wood :

1. The most commonly used pattern material is dried or seasoned wood.
2. The main reason for using wood for making patterns is its easy availability, low weight, and low cost. It can be easily shaped, worked, joined, and is relatively cheap.
3. By a rough estimate, more than 90% of the castings are, produced using wooden pattern.
4. The main disadvantage of the wood is that it absorbs moisture, because of which distortions and dimensional changes occur)
5. It has relatively lower life and is economical for the small quantity production.

Metal:

- Metal patterns are extensively used for the large quantity production of casting and for closer dimensional tolerances on castings.
- Metal patterns have much longer life and are free from major disadvantages of wooden patterns. Though many materials such as cast iron and brass can be used as pattern materials, aluminium is most commonly used as it can be easily worked, it is light weight and corrosion resistant.

Plastic:

- **Plastics** are used as pattern materials because of their low weight, easier formability, smooth surfaces, and durability.
- They do not absorb moisture and are dimensionally stable.
- Plastic patterns can be cleaned easily and have good corrosion resistance.

Polystyrene:

- Polystyrene (or expanded thermo Cole) is another pattern material, which has the special property that it changes to gaseous state on heating.
- Patterns made from polystyrene are *disposable* patterns that are suitable for single casting, like a prototype. Unlike other pattern materials, one pattern produces only one casting.
- It is very easy to make a pattern from polystyrene because it is soft.
- The pattern is not taken out of the mould to create the cavity. When the molten metal is poured in to the mould, the polystyrene transforms in to gaseous state, leaving negligible residue and the space occupied by the pattern is filled by the metal.

Types of patterns

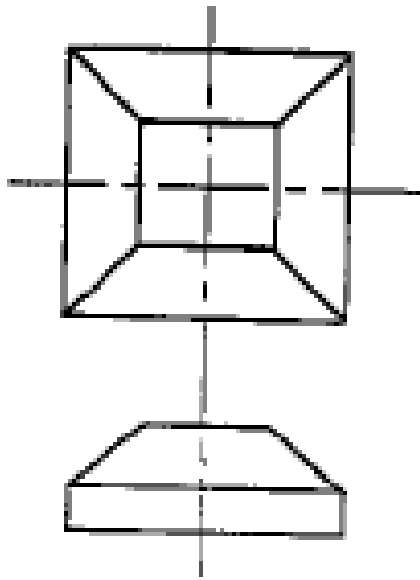

(a) Solid pattern

- The pattern used in foundry work can be classified into following categories:
- ***Solid pattern:*** This type of pattern is made as a single piece pattern, which has no partings or loose piece. A solid pattern is shown in Fig. Such patterns are generally used for castings of simple shapes. This pattern and the cavity produced by it are completely in the lower flask.

Split pattern:

Many patterns cannot be made in a single piece because of the difficulties encountered in removing them from the mould. To eliminate this difficulty, patterns are made in two parts, so that half of the pattern will be in the lower part of the mould and half in the upper part.

The split in the pattern occurs at the parting line of the mould. the two parts are aligned by means of Dowel pins as shown in Fig.

In case of complicated castings, a pattern may be made in three or more parts. Such patterns are known as *multi-piece patterns*.

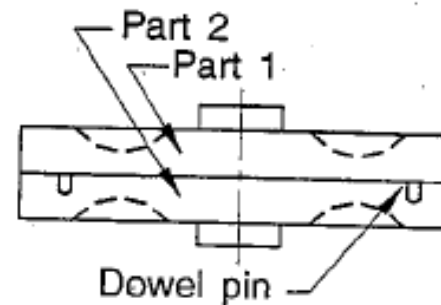

(b) Split pattern

Loose-piece pattern:

- **It is** a pattern with loose pieces, which are necessary to facilitate withdrawal of the pattern from the mould.
- A loose-piece pattern is shown in Fig. This type of patter used when the contour of the part is such that withdrawal of the pattern from the mould is not possible.
- This type of pattern is also used in situations where the casting is having projections, undercuts, or other configurations that would otherwise hinder the removal of the pattern.

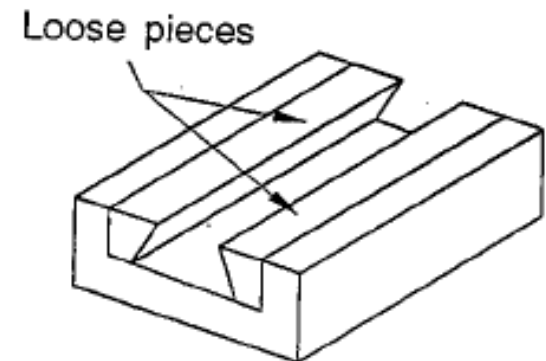

(c) Loose-piece pattern

Gated pattern:

- For producing small-sized castings, in one mould many cavities may be made . This is done by making a gated pattern in which number of small patterns, of the desired casting, are attached to a single runner by means of gates.
- Generally, gated patterns are made of metal to make them strong, A gated pattern for eight small castings is shown in Fig.

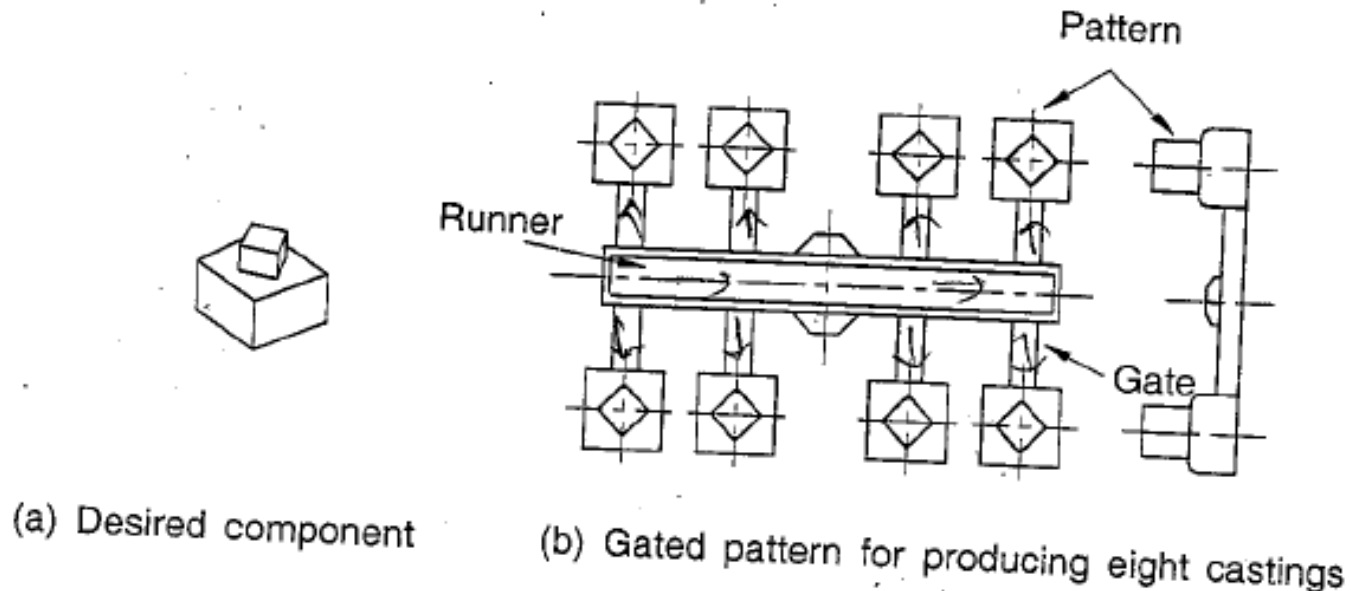

Match plate pattern:

- When the split patterns are attached on either side of the match plate, it is called as *match plate pattern*.
- A *match plate* is a plate on which two halves of a split pattern is mounted, on either side, such that one side is used to prepare one flask and the other side is used to prepare other flask. This facilitates perfect alignment and easy removal of pattern.
- Match plate patterns speed up production and help in maintaining uniformity in the size and shape of the castings.

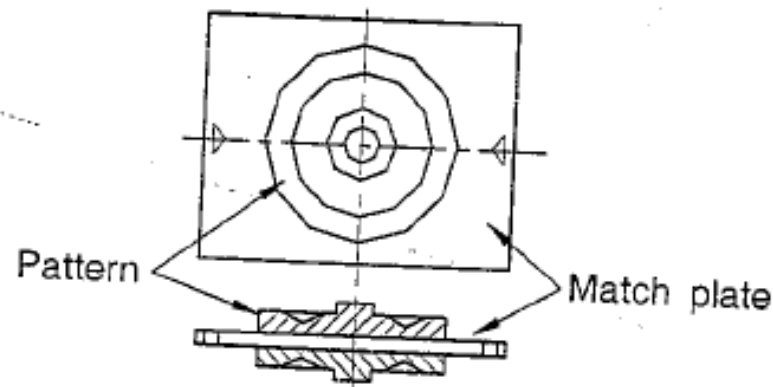

(c) Match plate pattern

Removable & Disposable Pattern

Patterns used in foundry can be classified as:

- **Removable Pattern:**

It is used for producing multiple identical moulds. The sand is packed around the pattern and the pattern is withdrawn from the sand leaving the desired cavity. The cavity produced is filled with molten metal to create the casting.

Disposal Pattern:

In this case the patterns are made from polystyrene or other materials and sand is rammed around them. The pattern is left in the mould instead of being removed from the sand. The pattern material vaporizes when the molten metal is poured in to the mould and the cavity thus created is filled with molten metal. The method is also known as full mould process or cavityless.

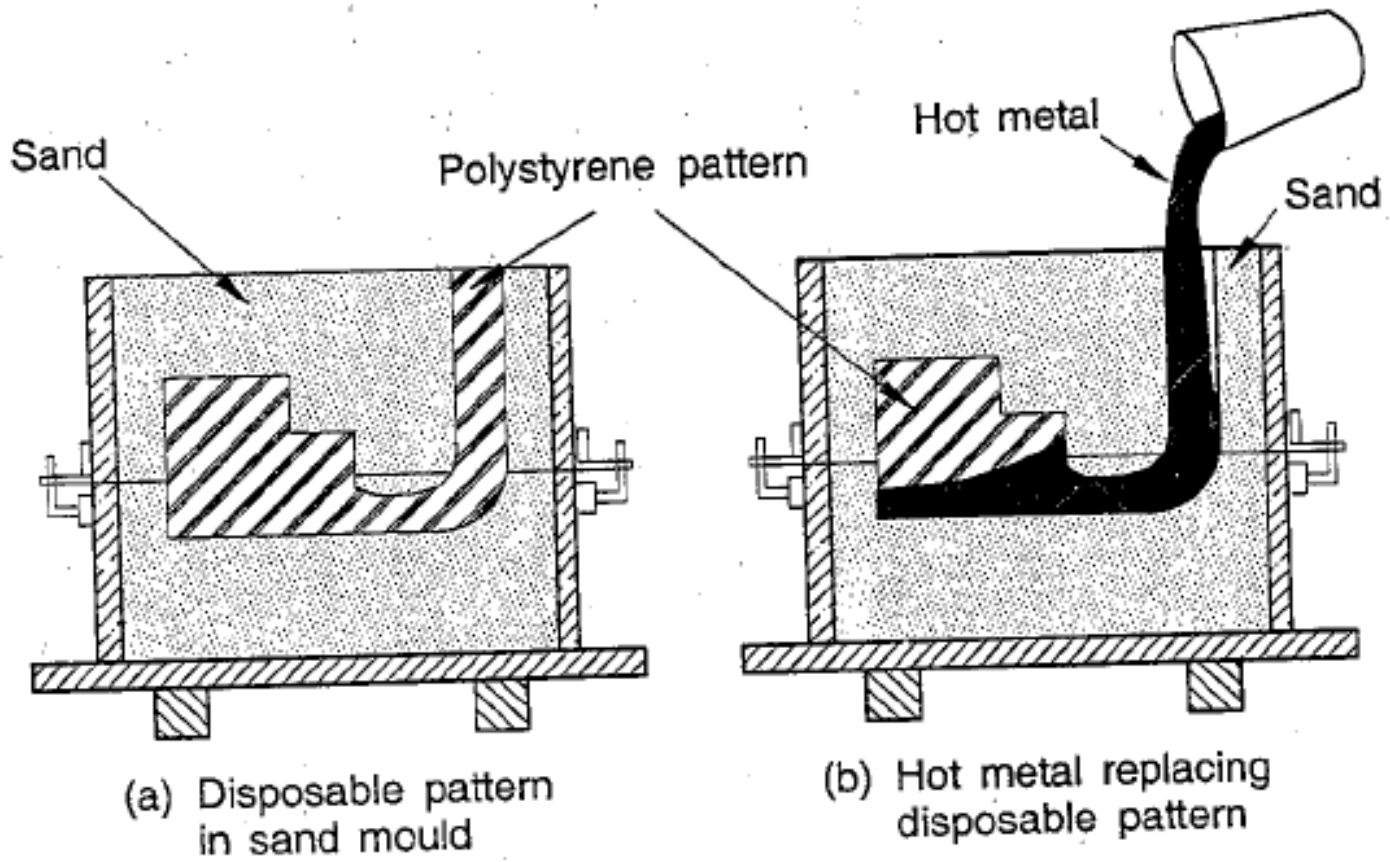

Pattern Allowances

Pattern allowances are one of the most important issues of the pattern design.

It affects the dimensional characteristics and shape of the casting.

Shrinkage Allowance: (contraction allowance)

All metals used for casting shrink after solidification in the mould and therefore, the pattern must be made larger than the required casting.

The pattern size is increased by an amount equal to the shrinkage of the specific metal from its melting point to room temperature.

- The shrinkage allowance differs from metal to metal.
- The amount of allowance provided depends upon the type of material, its composition, and pouring temperature.
- Shrinkage allowance is 1 to 2 % for gray cast iron and non ferrous castings and 2 to 3 % for steel castings.

Machining allowance

- *Machining allowance* or *finishing allowance* is the extra material added to the certain parts of the casting to enable their machining or finishing to the required size, accuracy and surface finish.
- The amount of allowance provided depends upon the casting method used, size and shape of the casting, type of material, machining process to be used, degree of accuracy and surface finish required.

Draft or taper allowance

- The *draft allowance or taper allowance* is the taper provided on the vertical faces of the removable patterns so that the pattern can be withdrawn from the rammed sand without causing damage to the vertical sides and without the need for excessive rapping.
- Draft provides a light clearance for the vertical sides of the pattern as it is lifted up.
- Typical draft allowance on patterns ranges from 1° to 3° for wooden patterns.

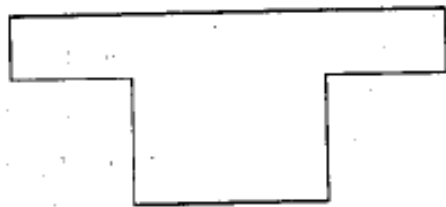

(a) Pattern with zero (no) draft



(b) Pattern with draft

Distortion allowance

- This is provided on patterns whose castings tend to distort on cooling. This happens due to unequal rate of cooling in different parts of the castings.
- Generally, distortion allowance is required for flat, long, and U and V shaped castings. The pattern itself is distorted suitably to yield a proper shaped casting.

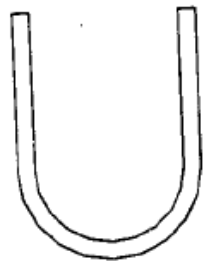

(a) Required shape of casting

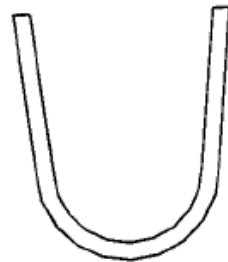

(b) Casting produced when no distortion allowance is provided

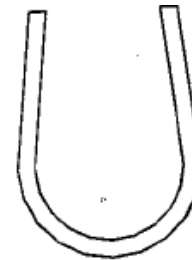

(c) Pattern with distortion allowance

Rapping or shake allowance

- During moulding, to withdraw the pattern from the rammed sand, it is rapped to loosen it from the sand, so that it can be easily withdrawn from the mould cavity without damaging the mould walls. When a pattern is rapped for easy withdrawals, the mould cavity is enlarged. To account for this increase in size of cavity, the pattern size is reduced, i.e. the pattern is made smaller by an amount equal to the mould enlargement that may take place during rapping.
- This allowance is important in large-sized or precision castings.
- The amount of rapping allowance depends upon factors such as extent of rapping, degree of compaction of sand, and size of mould, most of these are difficult to evaluate.

Moulding Sand

- Sand is the principle material used in the foundry for making moulds.
- Moulding sand possesses the necessary properties-high fusion temperature and good thermal stability-for making moulds.
- The principle ingredients of moulding sand are: silica sand grains, clay, moisture, and special additives like coal dust-to improve surface finish, fuel oil-to improve mouldability, and pearlite-to improve thermal stability.

Types of moulding sand

- **Moulding sand** is available in nature and it can also be manufactured artificially.
- Moulding sand found in nature is called *natural moulding sand* and the moulding sand prepared artificially, is known as *artificial or synthetic moulding sand*.
- **Natural moulding sand** is taken from riverbeds or are dug from pits. It is also obtained by crushing and milling soft yellow sandstone and rocks.
- **Synthetic sands or artificial sand** can be prepared in the foundry shop by crushing sandstone and then washing and grading these to yield a sand grade of required shape and grain distribution. The desired strength and bonding properties of this sand are developed by additive materials. This allows greater flexibility in the properties such as permeability, dry strength, and so on, which can be easily varied as desired.
- Synthetic sand is more expensive than natural sand.
- Moulding sand can be classified, according to its use, and composition, into the following categories:
 1. **Green sand**
 2. **Dry sand.**
 3. **Loam sand.**
 4. **Parting Sand**
 5. **Core Sand**

Green sand.

- It consists of silica sand with 18-30% clay and 4-8% water. Clay and water furnish the bond for green sand.
- Green sand retains the shape given to it.
- The name 'green sand' implies damp or undried sand, as the mould made from this sand is used immediately to pour the molten metal. It is not a green coloured sand.
- The moulds using this sand are called as *green sand moulds*.
- Green sand is collected from natural resources. It has the advantage of maintaining moisture content for a long time.

Dry sand

- Green sand that has been dried or baked after the mould preparation is called *dry sand*.
- Dry sand yields porosity absent castings, as there is no moisture.
- These are suitable for large-sized castings, say, heavier than 500 kg.

Loam sand.

- When clay and silica are mixed in equal proportions with little or no special additives, it is called *loam sand*.
- It is used for loam moulding.

Parting Sand

- Parting sand is used to keep away the green sand from sticking to the pattern and to allow the sand on the parting surface of the flask to separate without clinging.
- This permits easy withdrawal of the patten after ramming.
- Parting sand is free from clay and is dry.

Core Sand

- Sand used for making core is called core sand.
- Core sand should be stronger than the moulding sand.
- To make core sand, core oil, which is composed of linseed oil, resin, and other binding materials, is mixed with silica sand.

Properties of moulding sand

Moulding sand or foundry sand should possess certain properties to produce good moulds and castings.

These properties are:

Cohesiveness or strength:

The ability of sand particles to stick together determines the cohesiveness or strength of sand.

Moisture and clay content determine the strength of moulding sand.

Chemical Resistivity:

the sand used for moulding should be inert and should not react chemically with the metal/alloy being poured into it.

Permeability:

The property of a sand to allow easy flow of gases and vapours through it, is called permeability.

Flowability:

the capacity of the moulding sand to flow to different corners and intricate details on pattern without much special effort is an important requirement of moulding sand. This property of sand is known as flowability.

Adhesiveness:

The sand particles adhere to the mould box surface by the property called adhesiveness. This property helps the sand to retain the mould cavity and stay in the box.

Refractoriness:

Sand must not fuse when it comes in contact with molten metal. As sand should withstand the liquid metal temperature while it is poured, the moulding sand should have sufficient refractoriness.

Collapsibility:

After solidification of the molten metal, the casting is required to be removed from the mould. If the moulding sand is easily collapsible, free contraction of the metal as well as easy removal of the casting is possible.

Mold for a sand casting

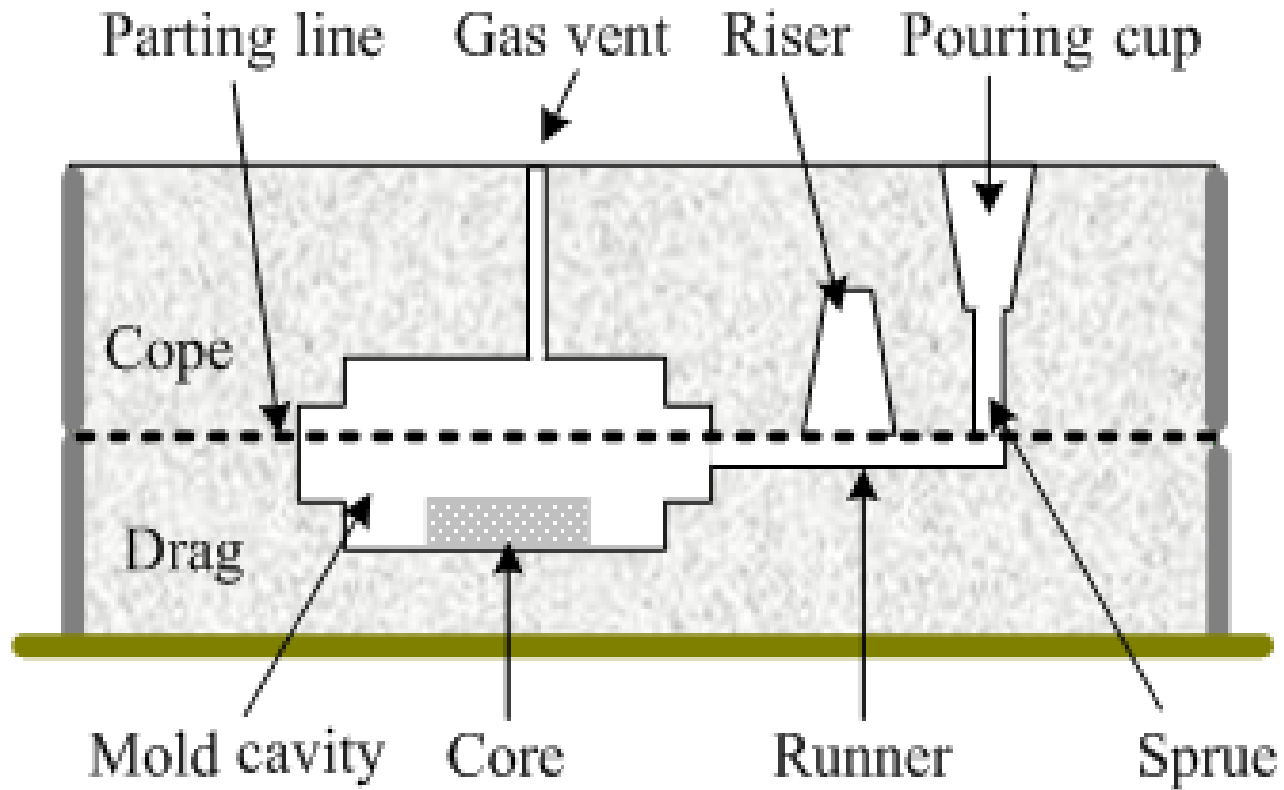

Moulding

- Moulding is the process of making a mould with the desired cavity in a suitable material, like sand, to pour the molten metal.

Types of moulds:

The principal raw material used in moulding is the moulding sand.

Depending upon the raw material used for preparing the mould, moulds may be classified as *Green sand mould, dry sand mould, loam mould and metal mould.*

Green sand mould:

- moulds are made using green sand
- Green sand permit easy patching and finishing of moulds
- Used for small and medium sized castings

Dry sand moulds:

- These moulds are prepared using green sand
- Green sand is dried or baked to remove all the moisture it contains.
- Used for large castings
- Only metallic flask are used since it requires baking even before being used.

Loam Mould:

- The mould is first built – up with bricks or large iron parts. These moulds are plastered with loam sand.
- Loam sand moulds is dried very slowly and completely before it is ready for casting.
- It takes very long time to prepare loam moulds.
- Used for large castings.

Metal mould:

these metals are made of metal and used for die casting, permanent mould casting, and centrifugal casting processes.

TOOLS USED IN MOULDING

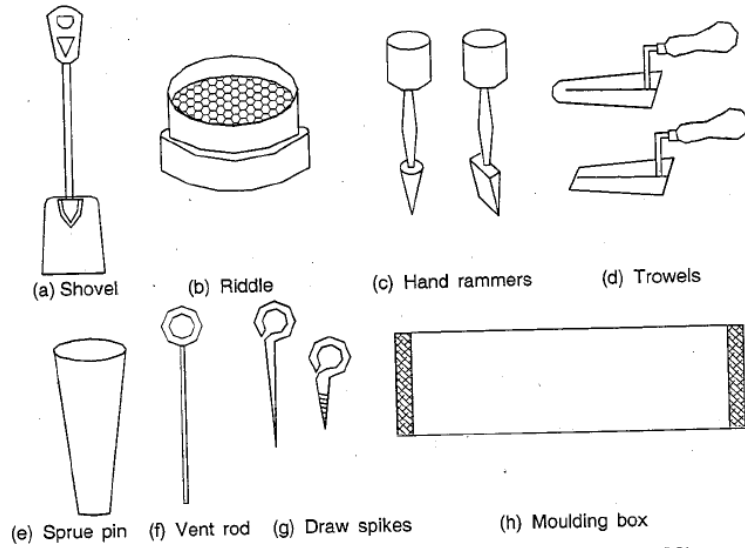

Figure 11.7 Some common tools used in foundry for moulding.

- **Shovel:** it is used for mixing moulding sand and for filling moulding sand into the flask.
- **Riddle:** it is used for removing foreign sand and from the moulding sand.
- **Rammers:** this is used for packing or ramming the sand into the mould.
- **Trowel:** A trowel is used for smoothening the surfaces of the mould.
- **Sprue pin:** It is a conical wooden pin, which is used while making the mould, while making an opening to pour the molten material into the cavity.
- **Vent rod:** this is used for making small holes to permit gases to escape while molten material is being poured.

- **Draw Spike:** this is used for drawing patterns from the sand.

- **Moulding Boxes:** (moulding Flasks)

moulding boxes are rigid frames made of iron or wood to hold the sand. The purpose of a flask is to impart necessary rigidity and strength to the rammed sand.

The top flask is called **cope** and the bottom flask is called **Drag**.

If the boxes are made of three sections then the middle one is called as **cheek**.

Procedure for making a mould

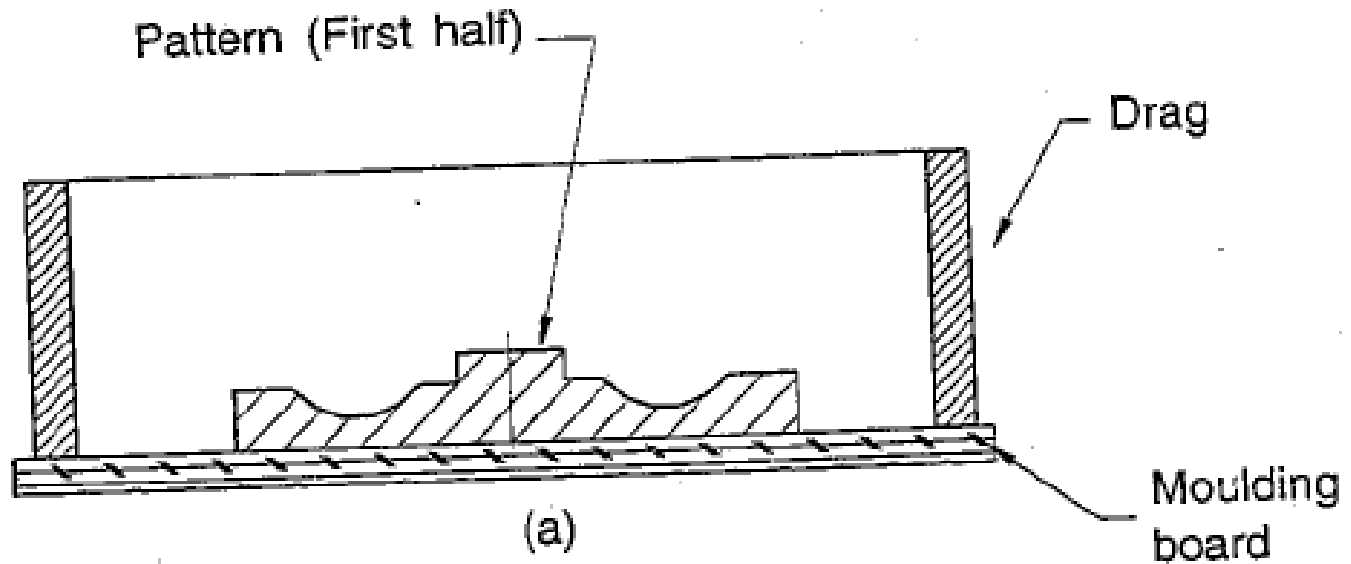

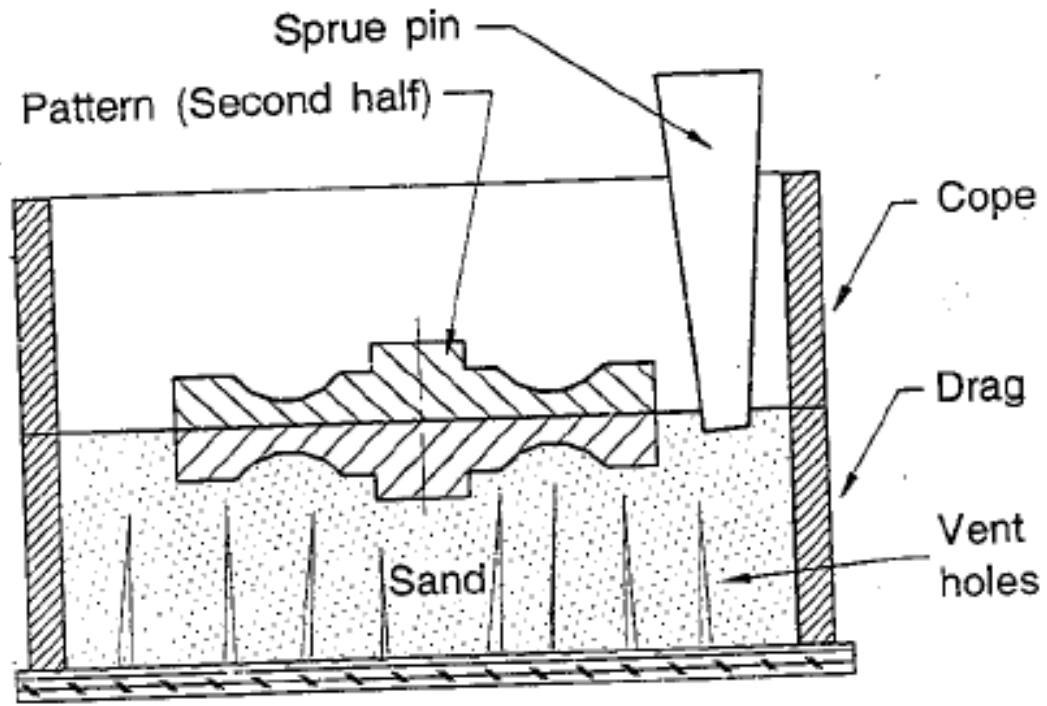

(b)

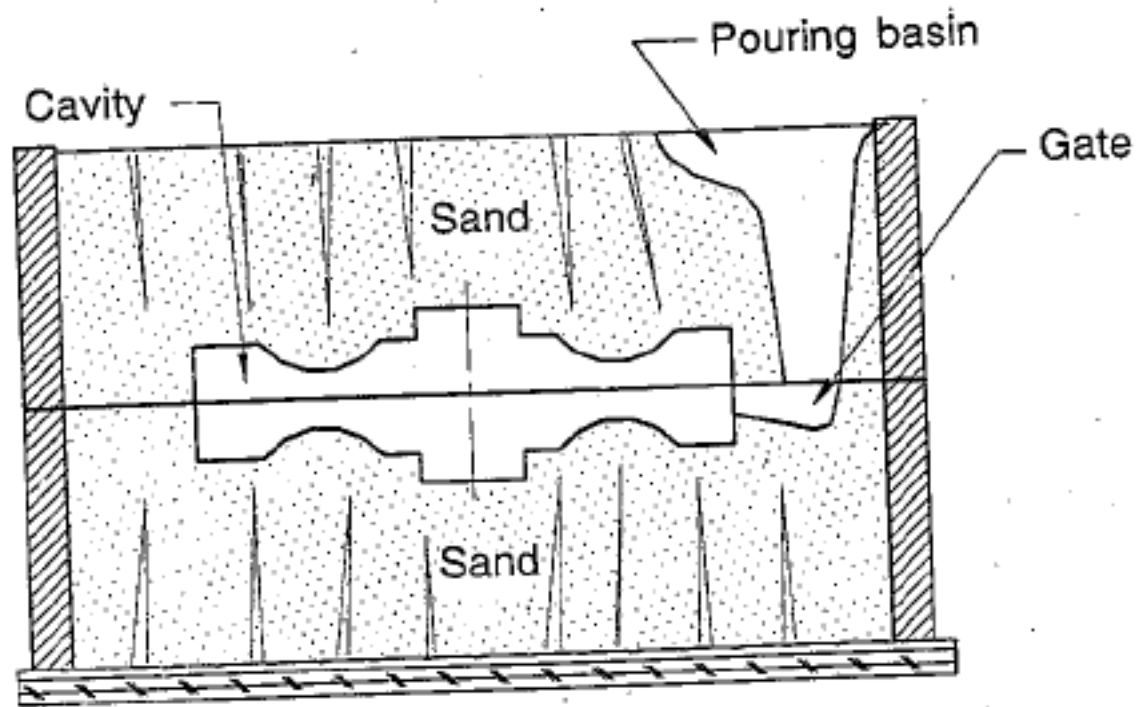

(c)

Mold for a sand casting

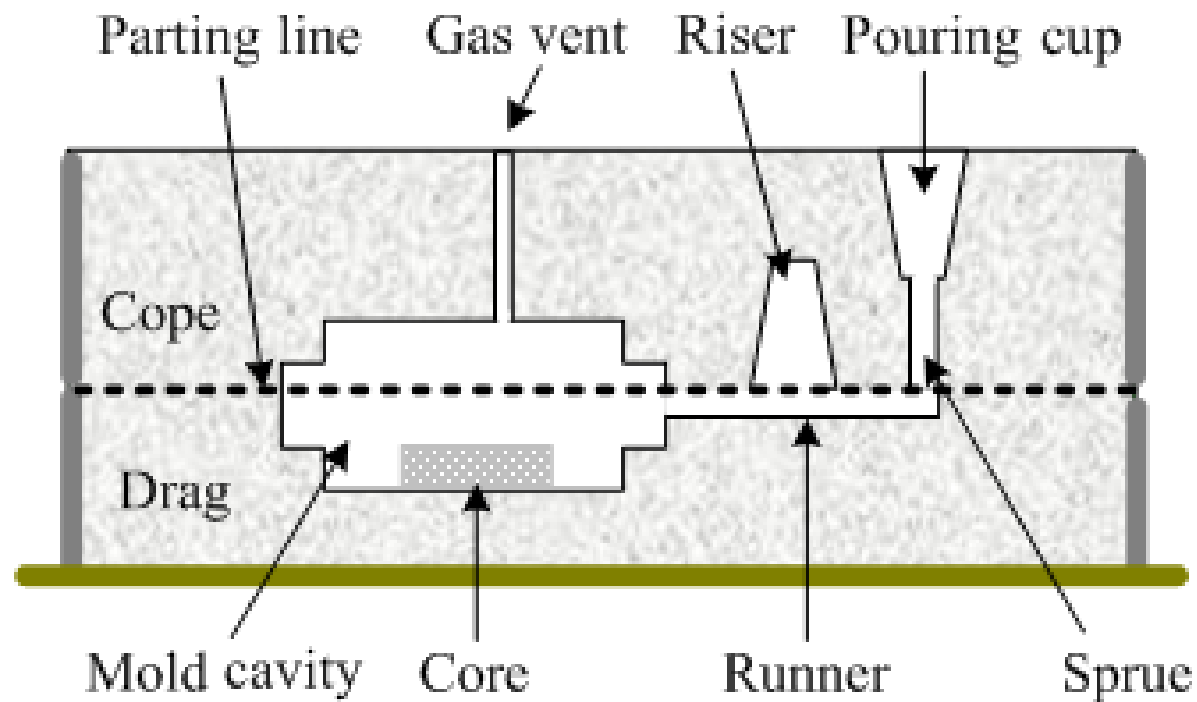

Moulding Processes

The common moulding processes are:

1. Bench moulding
2. Floor moulding
3. Pit moulding

Bench moulding

- Moulds are prepared on suitable benches
- Used for small moulds, which are light and can be easily handled
- Used for making green sand, dry sand or skin dried moulds
- Slow and laborious method.

Floor moulding

- Used when moulds are larger and cannot be accommodated on benches.
- Medium and larger moulds are prepared
- Green or dry sands are used
- This is also a slow method

Pit moulding

- Used for big castings, which cannot be made by flasks
- Mould cavity is prepared in a pit dug in the earth floor of the foundry
- Used for making sand moulds.

Types of moulding operations

There are two types of moulding operations:

1. Hand moulding
2. Machine moulding

Hand moulding:

- All the moulding operations are performed manually.
- It is slow, laborious and time consuming.
- It is difficult to obtain uniform hardness in moulds by hand ramming.
- Initial cost is low and simple tools are used.

Machine moulding

- For faster and uniform quality moulds
- Uses various moulding machines for preparing moulds.
- The majority of operations like ramming the sand, pattern withdrawal, and the finishing operations are done by machines.
- The operation is very fast, homogeneous and suitable for any size of casting.
- Initial cost is high and difficult shapes cannot be obtained.

CORES

- To get holes or other internal cavities in castings, cores are used.
- A core may be defined as a sand shape or form, that makes the contour of a casting for which no provision has been made in the pattern.
- Cores are placed in the moulds in specially created cavities called core prints.
- Cores may be made from sand, metal, plaster or ceramics.
- Core is like an obstruction placed and positioned in the mould.

Properties of Core

A good core must possess the following properties:

1. It must be strong to retain the shape while handling.
2. It must resist erosion by molten metal
3. It must be permeable to gases
4. It must have high refractoriness.
5. It must have good surface finish to replicate it on to the casting.

Core Making

- Cores are made of clay-free silica sand, which is thoroughly mixed with suitable binders, water and other ingredients to produce a *core mix*. This core mix is packed in to a *core box* that contains a cavity of desired shape.
- Core making consists of the following operations:
 1. Core sand preparation
 2. Core making
 3. Core baking.

Gating System

- Gating system refers to all the passageways through which the molten metal passes to enter the mould cavity.
- Different components of gating system are:
 - Pouring Cup
 - Sprue
 - Sprue base
 - Runner
 - Gate
 - Riser

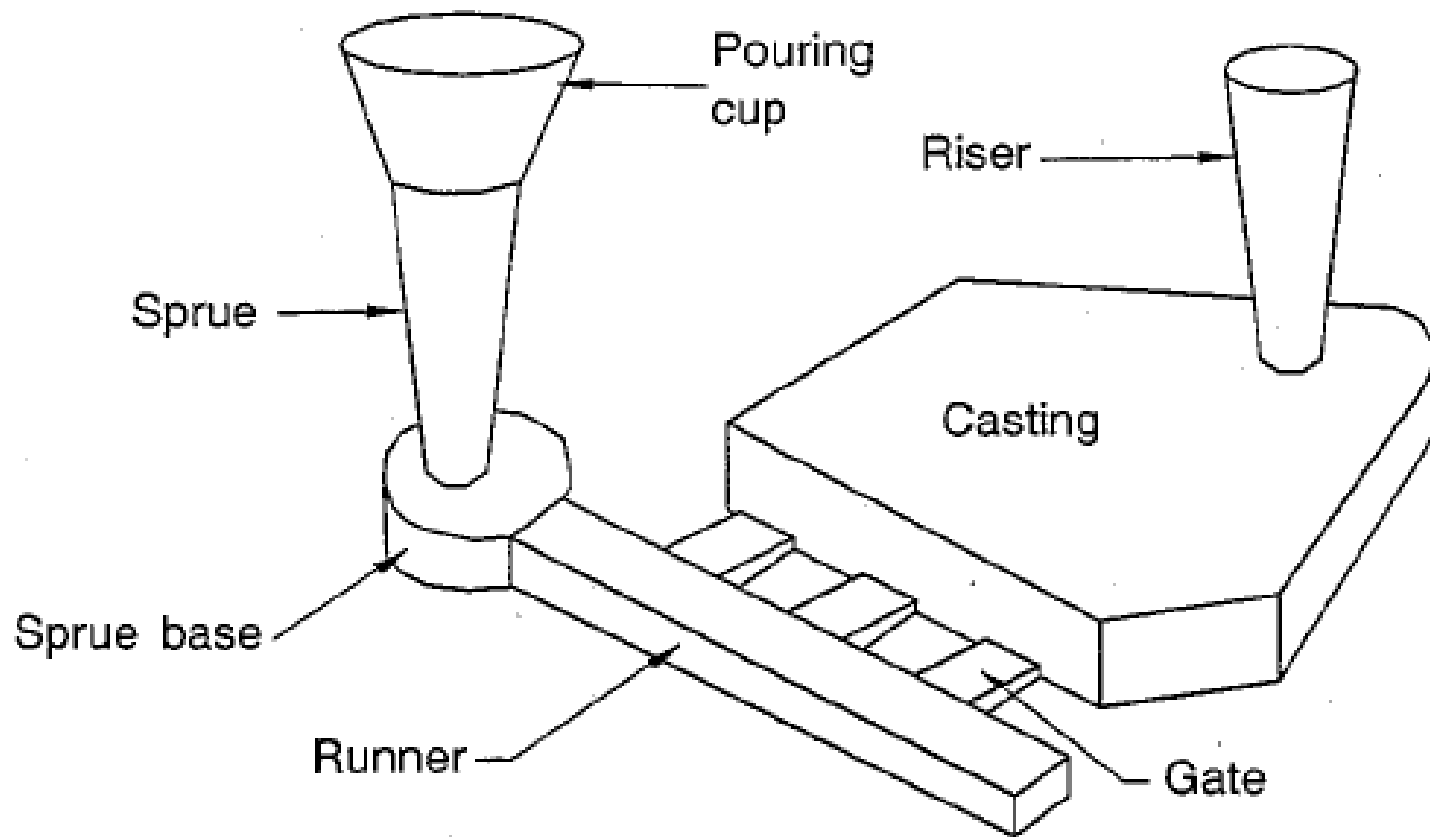

Components of gating system.

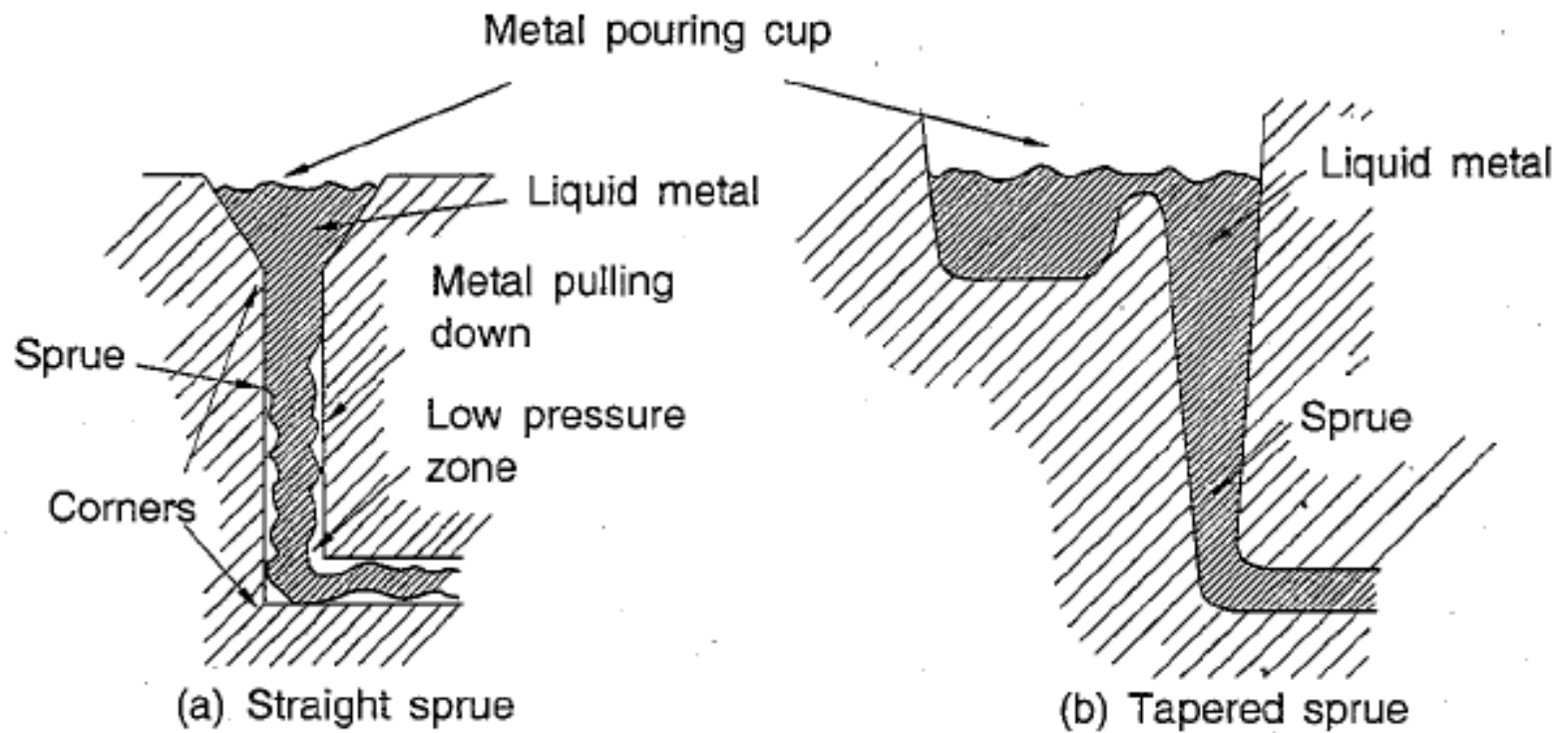

Types of sprue.

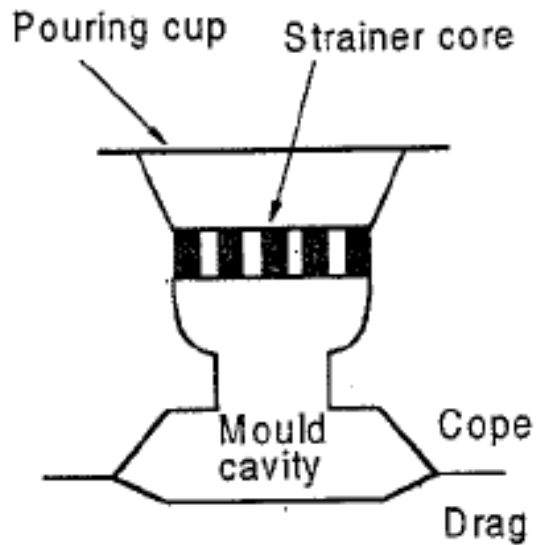

(a) Top gate

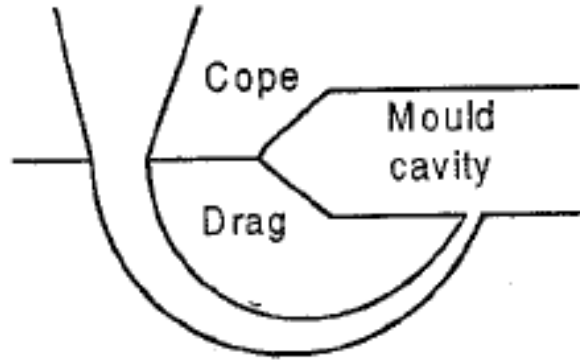

(b) Bottom gate

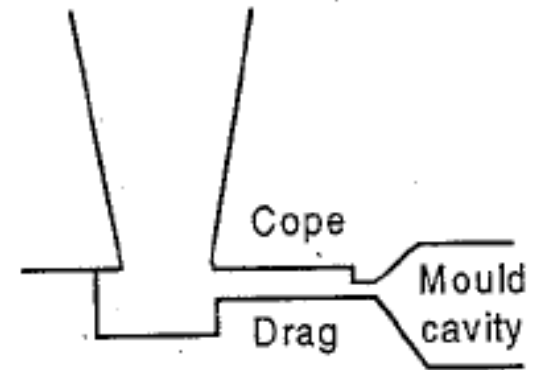

(c) Parting gate

Different types of gates.

Directional solidification

The contraction of the metal or volumetric shrinkage takes place in three stages:

- **Liquid contraction:** it occurs when the molten metal cools from the temperature at which it is poured to the temperature at which solidification commences.
- **Solidification contraction:** it takes place during the time the metal changes from the liquid state to the solid, i.e., when the metal loses its latent heat.
- **Solid contraction:** it takes place when the solidified metal cools from solidification temperature to room temperature.

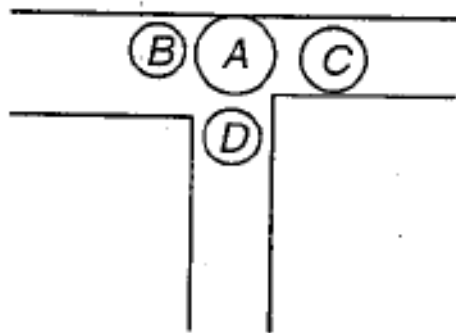

(a)

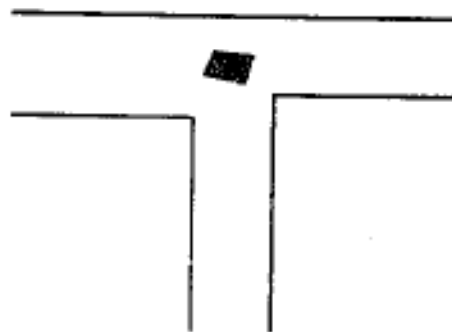

(b)

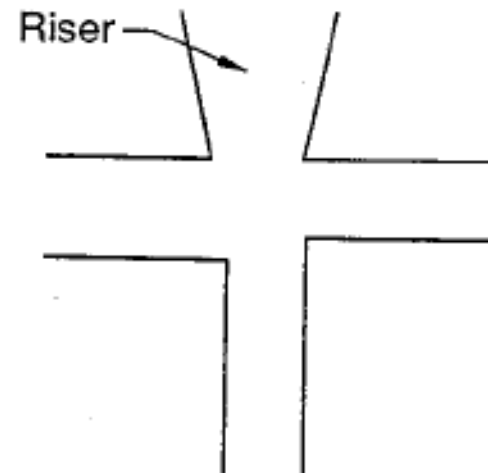

(c)

Design for directional solidification.

Solidification Time

$$t = c \left(\frac{\textit{Volume}}{\textit{Surfacearea}} \right)^2$$

Where C is a constant that depends up on the mould material, metal properties and temperature.

Casting Yield

$$C_y = \frac{W_c}{W_c + W_g} \times 100\%$$

where

W_c = weight of casting

W_g = weight of material in gating system (sprue, runner, gate, riser, etc.).

Casting Yield:

It is defined as the ratio of the casting mass to actual mass of the metal that has entered the mould cavity

Defects in casting

- Blow holes – smooth walled, round voids or cavities
- Shrinkage defects
- Hot tears – internal or external cracks
- Misruns, cold shuts and pour short
- Inclusions – separate undesirable foreign material

Advantages of Casting process

1. There is no restriction on the type of metal or alloy for the casting process. In other processes, like forging, only a ductile material can be shaped and a brittle metal like cast iron cannot be forged or hard materials cannot be machined.
2. There is no restriction on the size of the component for the casting. Products weighing from few grams to many tons can be produced by the casting process. There are severe problems in manufacturing larger parts by the forming or machining processes.
3. Casting process is economically suitable for both the small quantity job productions as well as for the mass production.

Disadvantages

1. Casting is a very high energy consuming process. For example, about 2000 kWh of power is required to produce a ton of finished steel castings.
2. Casting process is a highly labour-intensive compared to the other processes.
3. The quantum of raw materials required for producing castings is quite high, and needs large buildings, handling systems, large space, and inventory costs. For example, for producing one ton of steel castings about 2.2 tons of metal, 0.3 ton of parting sand, and 4 tons of moulding sand are needed apart from fuel and many other materials.
4. Time involved for manufacturing is more when compared to the machining processes.
5. The environmental pollution is high.

